

M
**CRANE
SYSTEMS**

mercan Makina Ve Sanayi Ürünleri İç Ve Dış Tic. Ltd. Şti.



Motor Katalogu KGE serisi

www.mercanvinc.com.tr

- Voltaj modifikasyonları, 50 Hz / 60 Hz
- İzolasyon sınıfı F, opsiyonel H
- Siparişe göre çalışma zamanı: 25%/150 h¹, 30%/180 h¹ or 10/25%/180h¹
- Eksenel şaft hareketi 0,5±1,0 mm
- IP 54, IP 22 fren koruması (EN 60529)
- Flanş bağlantılı - IM B5 (EN60034-7)
- Opsiyonel termal koruma

Kullanım alanları : Vinçler, kaldırma sistemleri kaldırma makinaları ve genel kullanım

- Voltage modifications: 50 Hz / 60 Hz
- Insulation class F, optional H
- On request the duty cycle could be: 25%/150h¹, 30%/180 h¹ or 10/25%/180h¹
- Axial shaft run 0,5±1,0 mm
- IP 54, brake protection IP 22 (EN 60529)
- Flange joining IM B5 (EN 60034-7)
- Optional thermal protection

Application: Main lifting mechanism of electric wire rope hoists, winches and other lifting machines



Genel boyutlar / Overall dimensions

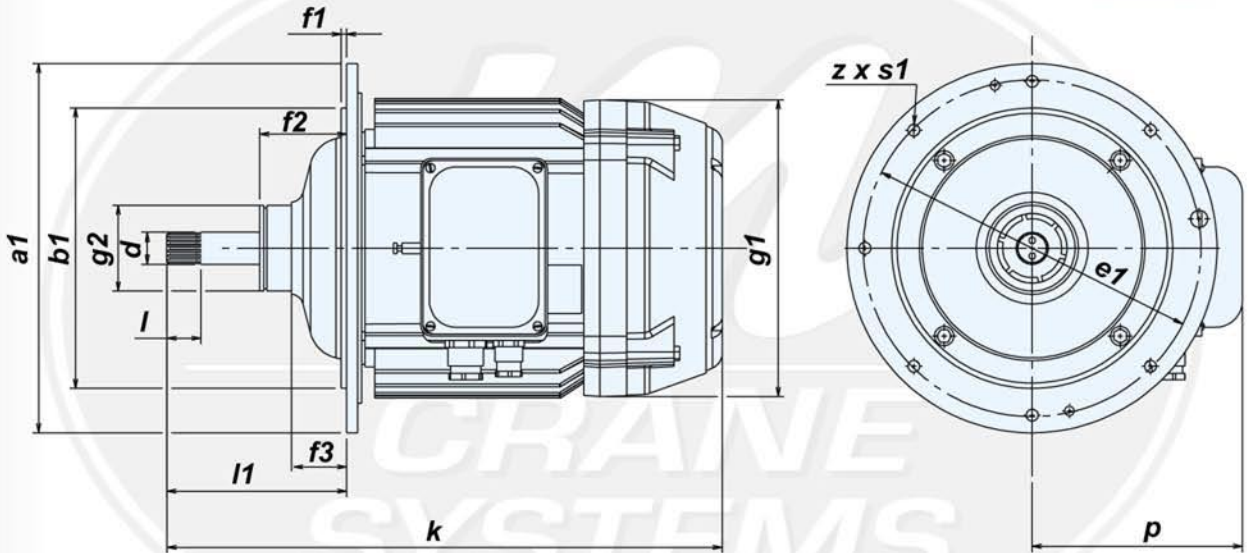

Tip Type	Boyutlar / Dimensions												Çıkış Mili / Shaft	
	a1	b1	e1	f1	f2	f3	l1*	g1	g2	k	p	z x s1	d	l
KGE 1605							109			350				
KGE 1608	260	185	226	4	73	44,4	125	230	75	382	165	8x9	Ee25x1,5x16S3aX	27
KGE II 1608							95			352				
KGE 2008							138			442				
KGE 2011	345	262	312	5	83	51,5	168	275	80	482	172	7x11	Ee30x1,5x18S3aX	32
KGE 2012							168			512				
KGE 2412	418	325	380	5	110	75	146	328	105	491	212	8x13	Ee40x2,0x18S3aX	38
KGE 2009							109			389	192			
KGE 2110	260	185	226	4	73	44,4	125	278	75	422	198	7x9	Ee25x1,5x16S3aX	27
KGE II 2110							95			392	198			
KGE 2612	345	262	312	5	81	51,5	140	328	80	508	220	7x11	Ee30x1,5x18S3aX	32
KGE 2714-6	505	365	460	6	145	102	215	376	120	596	266	11x15	Ee45x2,5x16S3aX	60
KGE 2714-4	418	325	380	5	110	75	146	376	105	527	252	7x13	Ee40x2,0x18S3aX	38
KGE 2714	345	262	312	5	81	51,5	168	366	80	566	226	7x11	Ee30x1,5x18S3aX	32
KGE 3317	418	325	380	5	110	75	146	418	105	579	257	8x13	Ee40x2,0x18S3aX	38
KGE 3517	505	365	460	6	145	102	215	438	120	631	266	11x15	Ee45x2,5x16S3aX	60
KGE 3518	505	365	460	6	145	102	215	438	120	637	266	11x15	Ee45x2,5x16S3aX	60

* Çalışma toleransı - max 2.5 mm / At operation mode. At idle mode the maximal tolerance is 2.5 mm

Teknik bilgiler 380V, 50Hz / Technical data at 380V, 50Hz

Güç Power	Tip Type	Devir sayısı Speed of revolution	Çalışma zamanı Duty cycle		Akım Current	Kalkış momenti Starting torque	Fren Momenti Braking torque	Ağırlık Weight
			CD	SF				
kW		min ⁻¹	%	sw/h	A	Nm	Nm	kg
0,75	KGE 1605-6	910	40	240	3,3	16,4	10,8	35
1,5	KGE 1608-6 KGE II 1608-6	910	40	240	5,8	25,0	23,5	40
3,0	KGE 2008-6	920	40	240	11,0	60,5	49	65
4,5	KGE 2011-6	920	40	240	12,3	78,0	78	70
8,0	KGE 2412-6	920	40	240	24,5	132	105	100
12,5	KGE 2714-6	920	40	240	36,0	200	165	155
25,0	KGE 3518P6	950	40	240	47,5	550	450	220
1,1	KGE 1605-4	1360	40	240	3,6	15	18	35
2,3	KGE 1608-4	1300	40	240	6,0	26	28	40
4,5	KGE 2008-4	1400	40	240	12,0	60	78	65
7,5	KGE 2012-4	1380	40	240	17,0	105	100	75
12,0	KGE 2714-4	1430	40	240	28,0	180	130	140
15,5	KGE 3517-4	1430	40	240	29,5	240	150	215
22,0	KGE 3517P4	1410	40	240	49,0	510	275	215
0,15/0,75	KGE 2009-30/6	165/930	10/40	240	4,0/4,0	14/15	12	48
0,30/1,5	KGE 2110-30/6 KGE II 2110-30/6	165/930	10/40	240	5,5/5,1	30/23	24	57
0,5/3,0	KGE 2612-30/6	165/930	10/40	240	10,0/8,5	52	48	101
0,8/4,8	KGE 2714-30/6	170/930	10/40	240	15,0/12,0	90	75	130
1,5/8,0	KGE 3317-30/6	170/940	10/40	240	30,0/19,0	140	125	195
0,15/1,1	KGE 2009-30/4	165/1400	10/40	240	4,0/4,0	14/16	15	48
0,30/2,2	KGE 2110-30/4 KGE II 2110-30/4	165/1400	10/40	240	5,5/7,0	30	30	57
0,5/4,5	KGE 2612-30/4	165/1400	10/40	240	10,0/11,0	52	55	101
0,8/7,5	KGE 2714-30/4	170/1400	10/40	240	15,0/15,0	90	90	130
1,5/12,5	KGE 3317-30/4	170/1430	10/40	240	30,0/28,0	140/180	135	195
0,16/0,75	KGE 2009-24/6	200/930	25/50	300	3,0/3,4	18	12	48
0,33/1,5	KGE 2110-24/6 KGE II 2110-24/6	200/930	25/50	300	3,7/5,0	29	24	57
0,7/3,0	KGE 2612-24/6	210/930	25/50	300	6,0/7,5	52	48	101
1,0/4,8	KGE 2714-24/6	200/940	25/50	300	11,0/12,0	100	75	130
1,7/8,0	KGE 3317-24/6	200/920	25/50	300	15,0/18,0	140	125	195
3,0/13,0	KGE 3517-24/6	220/960	10/40	240	40,0/30,0	215	180	215
4,0/16,0	KGE 3518-24/6	210/950	10/40	240	70,0/36,0	360/300	290	220
0,16/1,1	KGE 2009-24/4	200/1400	25/50	300	3,0/3,5	16	15	48
0,33/2,2	KGE 2110-24/4 KGE II 2110-24/4	200/1400	25/50	300	3,7/6,2	29	30	57
0,7/4,5	KGE 2612-24/4	210/1400	25/50	300	6,0/9,5	52	55	101
1,0/7,5	KGE 2714-24/4	200/1400	25/50	300	11,0/15,0	100	90	130
1,7/12,5	KGE 3317-24/4	200/1430	25/50	300	15,0/23,0	140	135	195
1,9/11,5	KGE 3517-24/4	225/1400	10/25	120	30,0/25,0	170/180	170	215
4.0/24.0	KGE 3518-24/4	210/1400	10/40	240	70,0/48,0	360/380	290	220



M
**CRANE
SYSTEMS**

mercan

Makina ve Sanayi Ürünleri İç ve Dış Ticaret Ltd.Şti.

Doğan Araslı Bulvarı, Fatih San. Sit. C-3 Blok No:30 Esenyurt - İstanbul-TÜRKİYE

Tel: + 90 (212) 428 62 30 - 31 - 32 • Faks: + 90 (212) 428 63 28

e-mail: info@mercanvinc.com.tr • www.mercanvinc.com.tr

www.mercanmakina.com.tr • www.mcranesystems.com.tr

www.mercanvinc.com.tr